

Temperature Sensor TI 300

Temperature range: up to 300 °C

This measurement system is used for the non-contact measurement of surface temperatures e.g. of tyres or brake discs based on IR-radiation. The sensor is integrated in an ambient temperature compensated module with mirror optics and additional IR-window in protection against contamination and condensation. Various connector options are available.



Mechanical data	
Dimensions	20 x 21 x 36 mm
Length L	100 ... 1500 mm
Weight	51 g

Electronic data	
Power supply	10 ... 12 V
Input current	2,5 mA
Output voltage swing	0 ... (Vsupply - 2) V
Typical output	0 ... 5 V
Response time	20 ms

Conditions for use	
Temperature range	-20 ... 300°C
Field of view	± 3°

Order numbers	
Front view:	
AS 6-06-05PN-HE	B 261 209 388
Offer drawing	A 261 209 388
Right view:	
AS 6-06-05PN-HE	B 261 209 389
Offer drawing	A 261 209 389

Working area

Spot size of the sensor for 90 % of irradiance from field view:

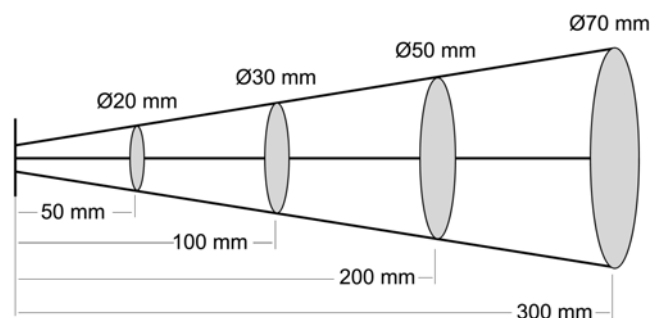

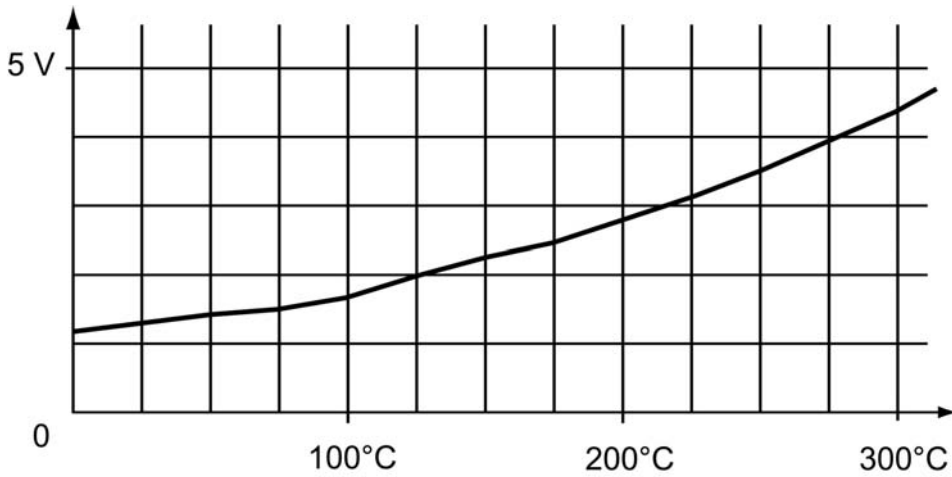

Tobject°C	Vout
-20	1,176
0	1,232
20	1,303
25	1,323
40	1,390
60	1,497
80	1,622
100	1,768
120	1,935

Tobject°C	Vout
140	2,123
160	2,332
180	2,562
200	2,813
220	3,085
240	3,377
260	3,689
280	4,021
300	4,371

